

**SUBMITTAL SHEET**

JOB NAME	ITEM TAG
JOB LOCATION	PART NUMBER
CONTRACTOR	DATE
ENGINEER APPROVAL	DATE

**BRASS GATE VALVE**

**Model T-400/S-400**

**Working Pressure, Non Shock (PSI)**

Cold working pressure (CWP): 200 PSI

Saturated steam (WSP):

Max temperature: 200 F



**NSF 61-8**



**Pictured Model T-400/S-400**

**MATERIAL SPECIFICATION**

PART	MATERIAL	SPECIFICATION
1	Body	Cast brass B584,C85700
2	Bonnet	Cast brass B584,C85700
3	Stem	Brass B16, C36000
4	Packing nut	Brass B16, C36000
5	Disc	Brass B124, C37700
6	Hand wheel	Cast iron A48 class 35
7	Wheel nut	Steel AISI 1010
8	Lock nut	Brass B16, C36000
9	Packing	NBR Commercial grade

**DIMENSIONS**

Size	A (IPS)	A (Cx C)	B	C
1/2"	1.54	1.62	2.72	2.13
3/4"	1.73	2.13	2.92	2.13
1"	1.85	2.48	3.31	2.13
1-1/4"	2.09	2.64	3.86	2.40
1-1/2"	2.25	2.96	4.57	2.96
2"	2.40	3.51	4.93	2.96
2-1/2"	2.80		6.03	3.19
3"	3.43		7.33	4.14
4"	3.96		8.67	4.41

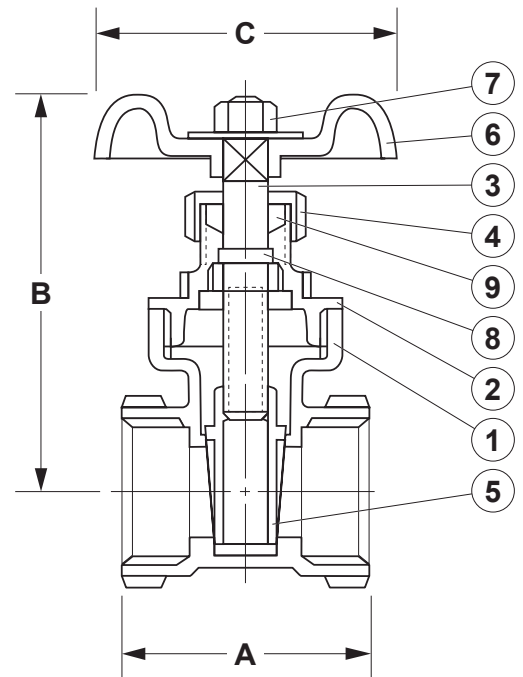

**Pictured Model T-400/S-400 Cut-away**